

Ductwork Questions & Answers

■ Sealing ■ Insulating ■ Benefits ■ How-to

We spend hundreds of dollars on energy efficient features, but recent studies on Southern homes show that we often overlook plugging the biggest energy waste—leaks in the ductwork for forced-air heating and cooling systems.

Q. Why is sealing the ductwork important?

A. Leaky ductwork often accounts for 10 to 30 percent of total heating and cooling costs. For an average home, leaky ducts can waste hundreds of dollars each year.

While the increase in energy costs is significant, protecting health and safety is the most important reason to seal ducts. Ducts are usually located in the attic, crawl space or basement. If the return ducts leak, they draw air from these areas directly into the home. This air can be contaminated with dust, mold, excess humidity, and potential toxins such as pesticides for termite treatment, combustion gases, and radon. When supply ducts leak, they can create a lower pressure inside the house which draws in contaminants, too.

Q. How do duct leaks affect heating and cooling equipment?

A. If the duct leakage is 20% of the total air flow, the efficiency of the cooling system can drop by 50%. Heating efficiency is similarly affected. Duct leakage also lowers the heating and cooling capacity, and can lessen equipment life. Many comfort complaints in homes are due to poor ductwork.

Q. How do I know if a system has duct leaks?

A. Start with a visual inspection of the system. Energy codes require that all joints in the ductwork be sealed. However, many leaks are not readily visible. To determine if you have serious leakage requires a pressure test of the ducts with a special fan.

The test involves temporarily taping over the registers, then blowing air into the ducts with the fan to determine the amount of leakage as well as the location of the leaks. The test takes about an hour. Some contractors conduct the test for a nominal fee or include it as part of a bid to seal leaky ductwork.

Q. Why is duct leakage so common?

A. Most connections are simply not sealed. There is also a problem with poor quality materials being used to seal ducts. Duct tapes do not provide a permanent seal. Their adhesive dries out. Experts recommend duct sealing mastic. Mastic is a thick paste which can be used on all duct materials and provides a permanent seal. Mastic comes in tubs and tubes and costs around \$10 per gallon. For new construction, the cost of material and labor to seal all the joints with mastic should be about the same as for a quality job sealed with tape.

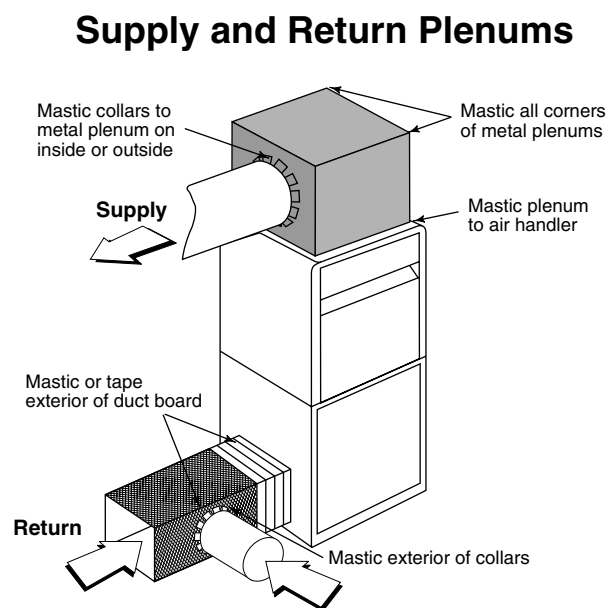
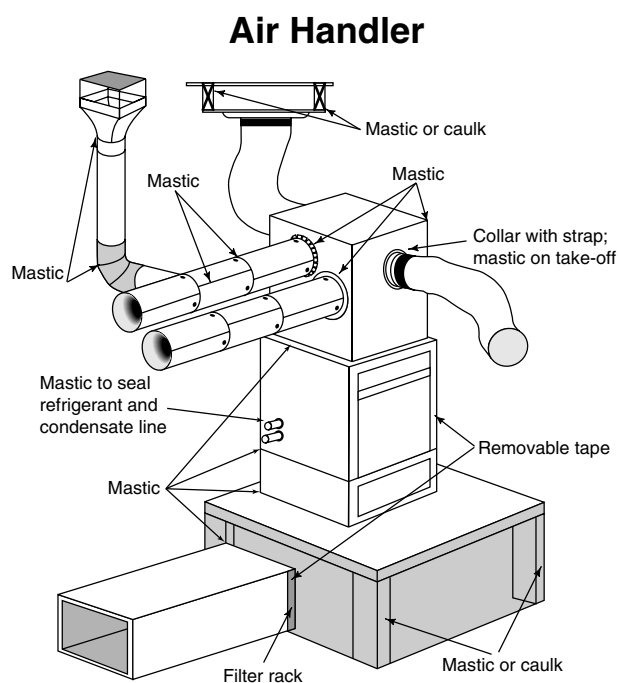

Flex Duct

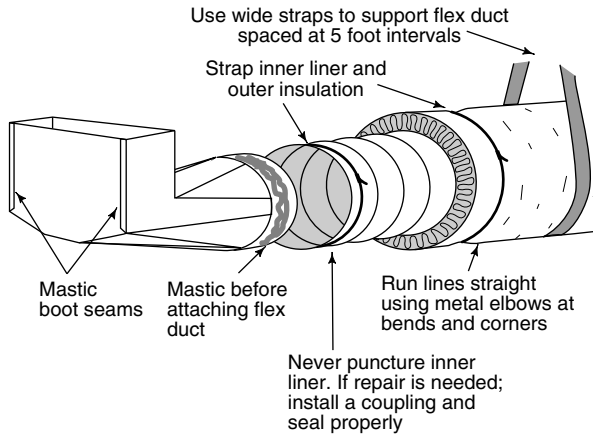

Boots

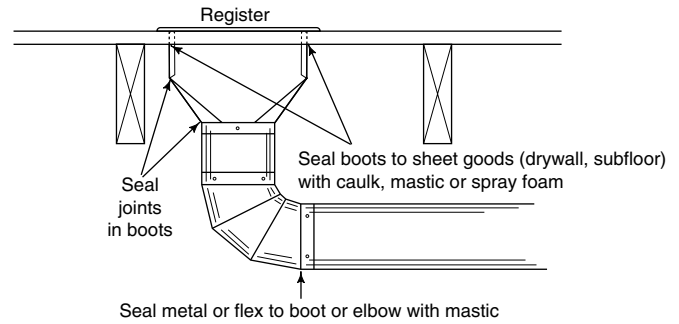

Q. If the ducts are insulated, do they need to be sealed?

A. Yes. Insulation does not stop air leaks. Look for dirt streaks in duct insulation—it's a sign that air has been leaking from the ducts.

Q. Are certain types of ducts more airtight?

A. Studies done across the Southeast show that all types of ductwork can have problems with air leakage. Mastic works to seal metal, flexible, and fibrous ductwork. Try to avoid using framing (such as panned returns) for ductwork as these create hard to seal leaks.

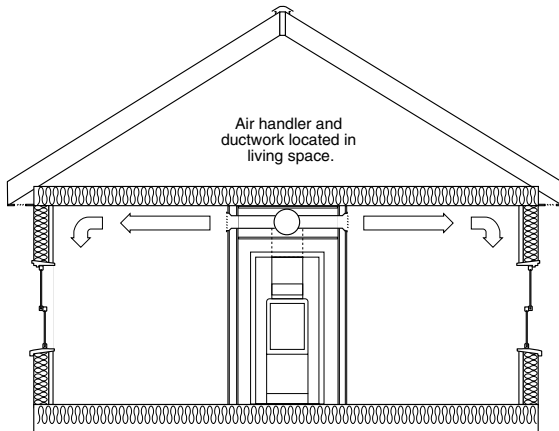

Q. Where is the best location for ductwork?

A. The problems due to leaky ducts can be reduced or eliminated by bringing the ducts inside the conditioned space. If that is not possible, the crawlspace or basement is usually preferred over the attic due to the summertime heat buildup in the attic. Exterior walls are bad locations for ducts because they displace wall insulation and can cause condensation problems.

Q. Where are the most important areas to seal?

A. Seal in this order:

High Priority Leaks

- Disconnected components
- Connections between air handling unit and the plenums
- All seams in the air handling unit, plenums and rectangular ductwork, especially in hard to reach places
- Return takeoffs, boots, and other connections, especially site-built items

Moderate Priority Leaks

- Joints between sections of branch ductwork

Low Priority Leaks

- Longitudinal seams in round metal ductwork